

Cuisinart®

INSTRUCTION AND
RECIPE BOOKLET



Cuisinart® Classic Toaster Oven Broiler

TOB-50

CONTENTS

Important Safeguards	1
Special Cord Set Instructions	2
Introduction	2
Features and Benefits	3
General Guidelines	4
Use and Care	
Broil	4
Bake	4
Toast	4
Browning Selection	4
Toast (continued)	5
Cleaning and Maintenance	5
Oven Rack Position Diagrams	5
Recipes	6
Warranty	19

IMPORTANT SAFEGUARDS

When using an electrical appliance, basic safety precautions should always be followed, including the following:

1. Read all instructions.
2. Do not touch hot surfaces. Use handles.
3. To protect against electrical shock, do not place any part of the toaster oven broiler in water or other liquid. See instructions for cleaning.
4. This appliance should not be used by or near children.
5. **UNPLUG FROM OUTLET WHEN NOT IN USE AND BEFORE CLEANING.** Allow to cool before cleaning or handling.
6. Do not operate any appliance with a damaged cord or plug or after the appliance has malfunctioned or has been dropped or damaged in any way or is not operating properly. Return the toaster oven broiler to the nearest Cuisinart Repair Center for examination, repair or mechanical or electrical adjustment.
7. The use of accessory attachments not recommended by Cuisinart may cause injury.
8. Do not use outdoors.
9. Do not let cord hang over the edge of the table or countertop where it could be pulled on inadvertently by children or pets, or touch hot surfaces, which could damage the cord.
10. Do not place toaster oven broiler on or near a hot gas or electric burner or in a heated oven.
11. Do not use this toaster oven broiler for anything other than its intended purpose.
12. Extreme caution should be exercised when using containers constructed of materials other than metal or glass in the toaster oven broiler.
13. To avoid burns, use extreme caution when removing tray or disposing of hot grease.

-
14. **When not in use, always unplug the unit.** Do not store any materials other than manufacturer's recommended accessories in this oven.
 15. Do not place any of the following materials in the oven: paper, cardboard, plastic and similar products.
 16. Do not cover crumb tray or any part of the oven with metal foil. This will cause overheating of the oven.
 17. Oversize foods, metal foil packages and utensils must not be inserted in the toaster oven broiler, as they may involve a risk of fire or electric shock.
 18. A fire may occur if the toaster oven broiler is covered or touching flammable materials such as curtains, draperies, and walls, when in operation. Do not store any items on top of the appliance when in operation. Do not operate under wall cabinets.
 19. Do not clean with metal scouring pads. Pieces can break off the pad and touch electrical parts, involving a risk of electric shock.
 20. Do not attempt to dislodge food when the toaster oven broiler is plugged into electrical outlet.
 21. Warning: To avoid possibility of fire, NEVER leave toaster oven broiler unattended during use.
 22. Use recommended temperature settings for baking and roasting.
 23. Do not rest cooking utensils or baking dishes on glass door.
 24. Turn the function dial to the off position to turn off toaster oven broiler.

SAVE THESE INSTRUCTIONS

Please read and keep these instructions handy. These instructions will help you to use your Cuisinart® Toaster Oven Broiler to its fullest so that you will achieve consistent, professional results.

SPECIAL CORD SET INSTRUCTIONS

A short power supply cord is provided to reduce the risks resulting from becoming entangled in or tripping over a longer cord.

Longer extension cords are available and may be used if care is exercised in their use.

If a long extension cord is used, the marked electrical rating of the extension cord must be at least as great as the electrical rating of the appliance, and the longer cord should be arranged so that it will not drape over the countertop or tabletop where it can be tripped over or pulled on by children.

NOTICE

This appliance has a polarized plug (one blade is wider than the other). As a safety feature, this plug will fit in a polarized outlet only one way. If the plug does not fit fully in the outlet, reverse the plug. If it still does not fit, contact a qualified electrician. Do not attempt to defeat this safety feature.

FOR HOUSEHOLD USE ONLY NOT INTENDED FOR COMMERCIAL USE

INTRODUCTION

You'll love how easily our Cuisinart® Classic Toaster Oven Broiler does everything from breakfast toast to family meals. Toast 6 slices of bread, bagels or muffins, or bake or broil a family-sized entrée. This countertop oven is big enough to handle many of your everyday full-size oven tasks. We've simplified the controls to make the whole process easier than ever. Check out our recipes in the back of the book, and enjoy!

FEATURES AND BENEFITS

- 1. Temperature Dial**
Select desired temperature for the “Baking” or “Broiling” function.
- 2. Function Dial**
Select cooking method – Bake, Broil or Toast.
- 3. Toast Shade Dial**
Select the desired toast shade – Light, Medium or Dark.
- 4. Toasting Start Button**
Push button to start toasting function.
- 5. Toasting Stop Button**
Push button to stop toasting in mid-cycle and shut off oven.
- 6. Oven On Indicator**
Indicator light will remain lit when oven is in use.
- 7. Oven Rack (not shown)**
Has two positions. The top position has a 50% stop feature so the rack stops halfway out of the oven. It can be removed by lifting the front of the rack and sliding it out.
- 8. Slide-out Crumb Tray (not shown)**
Slides out from bottom of the toaster oven broiler for easy cleaning.
- 9. Cord Storage**
Takes up excess cord and keeps countertop neat.
- 10. Easy-Clean Interior**
The sides of the oven are coated, providing an easy-to-clean surface.
- 11. Baking/Broiling Pan**
A baking/broiling pan is included for your convenience. The broiling pan's drip tray has two positions to accommodate a variety of meats, poultry, and fish for broiling.

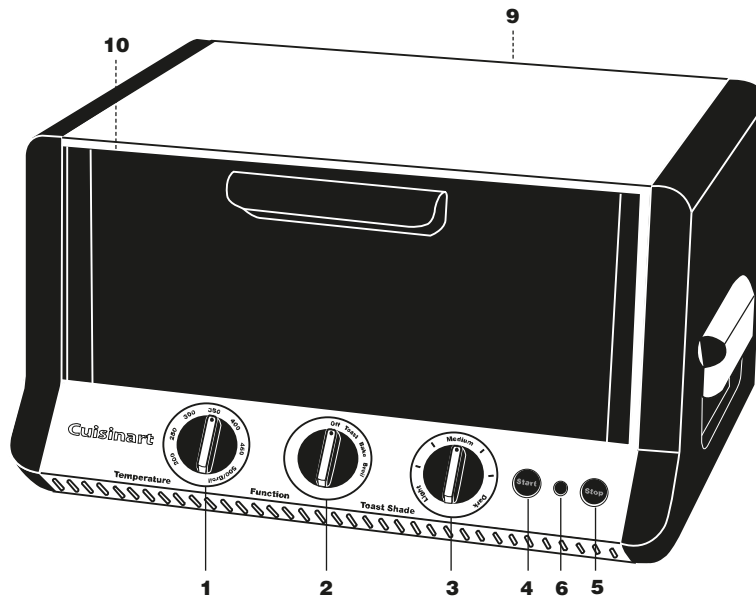

Broiling Pan and Drip Tray

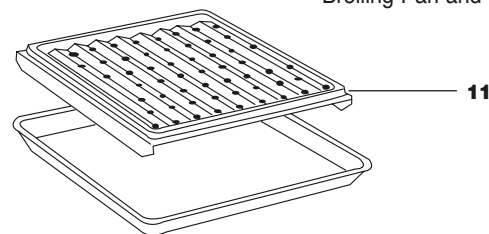

BEFORE THE FIRST USE

Place your oven on a flat surface.

Before using your oven, move it two to four inches away from the wall or from any objects on the countertop. Do not use on heat-sensitive surface.

DO NOT STORE OBJECTS ON THE TOP OF THE OVEN. IF YOU DO, REMOVE ALL OBJECTS BEFORE YOU TURN ON YOUR OVEN. THE EXTERIOR WALLS GET VERY HOT WHEN IN USE. KEEP OUT OF REACH OF CHILDREN.

GENERAL GUIDELINES

Baking: Baking function can be used as you would normally use your kitchen oven for roasting meats including chicken, or baking cakes, cookies and more.

Broiling: Broiling function can be used for beef, chicken, pork, fish and more. It also can be used to top brown casseroles and gratins. **Caution:** Aluminum foil is not recommended for covering the drip tray. Foil is extremely dangerous when broiling fatty foods. Grease will accumulate and may catch fire. The use of foil is not recommended, but if foil is used to cover broiling pan, be sure foil is tucked neatly around the pan and does not touch the walls or heating rods. Never cover crumb tray.

Toasting: Always have the rack in rack position “B”, as indicated in the diagram on page 5, for even toasting. Always center your item/items in the middle of the rack.

WARNING: Placing the rack in the bottom position or in the top position with the rack upwards while toasting may result in a fire. Refer to rack position diagram for proper use.

Turning off the toaster oven broiler: Turn the function dial to off. The indicator will turn off.

USE AND CARE

Unwind the power cord. Check that the crumb tray is in place and that there is nothing in the oven. Plug power cord into the wall outlet.

Broil

Note: When broiling, add approximately $\frac{1}{4}$ cup water to the bottom of the broiling pan to reduce sizzling and splattering. Place the drip tray in the broiling pan. Note: There are two positions for the drip tray so that a variety of thicknesses of foods can be broiled. Also, the oven rack can be turned up or down depending on the thickness of the food being broiled. In most cases the oven rack should be in the higher position (position “C” – see rack position diagram on page 5).

To broil, set temperature and function dials to broil. Preheat oven for five minutes with door closed. After the five-minute preheat period, place the broiling pan in the oven. Always leave door ajar when broiling.

Note: Never use glass oven dishes to broil.

To stop broil operation, turn function dial to off position.

Bake

To bake, turn the temperature dial to the desired temperature and turn function dial to bake position. Make sure oven rack is in position “A” – see rack position diagram on page 5. The oven indicator light will turn on. Preheat oven for five to ten minutes (time will vary depending upon desired temperature); then begin to bake.

Toast

To toast, make sure the oven rack is in rack position “B”, as indicated in the diagram on page 5. If toasting two items, center them in the middle of the rack. Four items should be evenly spaced – two in front, two in back. Six items should be evenly spaced – three in front, three in back. Close the glass door.

Browning Selection

Set function dial to toast. Turn toast shade dial to desired browning setting. Press “Start” button to begin toasting.

Stop Toasting

When the toasting cycle is finished, the oven will beep 5 times and turn off. If you wish to stop the toasting cycle before it is finished, simply press the “Stop” button. The toaster oven broiler will cancel your toast cycle.

Important Notes on Toasting

The oven rack must be in rack position “B” as indicated in the diagram on this page.

CLEANING AND MAINTENANCE

Always allow the oven to cool completely before cleaning.

1. Always unplug the oven from the electrical outlet.
2. Do not use abrasive cleansers, as they will damage the finish. Simply wipe the exterior with a clean damp cloth and dry thoroughly. Apply the cleansing agent to a cloth, not to the toaster oven, before cleaning.
3. To clean interior walls, use a damp cloth and a mild liquid soap solution or a spray solution on a sponge. Never use harsh abrasives or corrosive products. These could damage the oven surface. Never use Brillo pads, etc. on interior of oven.
4. To remove crumbs, slide out the crumb tray and discard crumbs. Wipe clean and replace. Crumb tray is dishwasher-safe. To remove baked-on grease, soak the tray in hot sudsy water or use nonabrasive cleaners. Never operate the oven without the crumb tray in place.
5. Wire rack, broiling pan and drip tray are dishwasher-safe. If heavily soiled, soak in hot sudsy water or use a nylon scouring pad or nylon brush.
6. Never wrap the cord around the outside of the oven. Use the cord storage cleats on the back of the oven.

IMPORTANT

After cooking greasy foods and after your oven has cooled, always clean top interior of oven. If this is done on a regular basis, your oven will perform like new. Removing the grease will help to keep toasting consistent, cycle after cycle.

All of our recipes have been tested in our kitchen and specially developed to work in the Cuisinart® Classic Toaster Oven Broiler. These mouth-watering recipes are just a sampling of what the Cuisinart® Classic Toaster Oven Broiler can do.

OVEN RACK POSITION DIAGRAMS

Each recipe gives you step-by-step directions and will even tell you where the oven rack should be positioned for best results.

Please refer to the diagram for oven rack positions.

Each position is described with a letter that is referred to in the recipe.

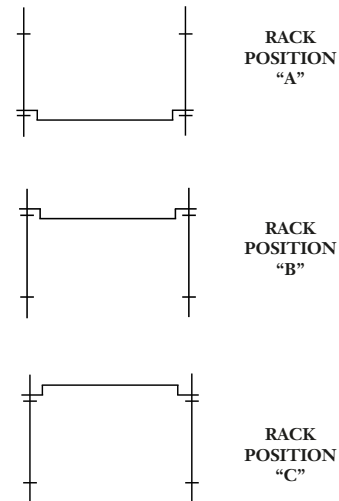

RECIPES

Jammy Muffins

Get your ingredients all ready to mix the night before – combine dry ingredients and cover; combine egg, milk, yogurt and vanilla; cover and refrigerate. In the morning mix and bake for fresh warm muffins.

Makes 6 regular muffins

- 1½** **teaspoons + 3 tablespoons granulated sugar**
- ½** **teaspoon ground cinnamon**
- cooking spray**
- 1** **cup unbleached all-purpose flour**
- 1¼** **teaspoons baking powder**
- ¼** **teaspoon baking soda**
- ⅛** **teaspoon salt**
- 1** **large egg**
- ¼** **cup lowfat milk**
- 2** **tablespoons plain lowfat yogurt**
- ¼** **teaspoon vanilla extract**
- 4** **teaspoons jam or marmalade (not jelly)**

Preheat toaster oven to 400°F. Combine 1½ teaspoons granulated sugar with cinnamon and reserve. Lightly coat a standard 6-cup muffin tin with cooking spray.

Place flour, 3 tablespoons granulated sugar, baking powder, baking soda, and salt in a medium bowl. Stir to blend. Place egg in a small bowl and stir until smooth. Add milk and yogurt to beaten egg and stir until smooth, then stir in vanilla. Add the liquid mixture to the dry ingredients and whisk until just smooth – do not overmix – the muffins can become tough and rubbery. Divide the batter evenly among the prepared muffin cups. Top each in the center with about ¼ teaspoon jam or marmalade. Sprinkle muffins with the sugar/cinnamon mixture.

Bake in toaster oven for 18 to 20 minutes, rotating the muffin tin after approximately 9 minutes. Turn out onto a rack and cool for at least 5 to 10 minutes (the jam will be hot enough to burn) before serving.

Nutritional information per muffin:

*Calories 138 (9% from fat) • carb. 28g • pro. 4g • fat 1g • sat. fat 0g
• chol. 36mg • sod. 196mg • calc. 46mg • fiber 1g*

Parmesan Chive Corn Muffins

These muffins are delicious served warm from the oven with soups or stews.

Makes six 2½-inch muffins

- cooking spray**
- ½** **cup all-purpose flour**
- ½** **cup yellow cornmeal**
- 2** **tablespoons firmly packed brown sugar**
- 1** **teaspoon cream of tartar**
- ¼** **teaspoon baking soda**
- ⅙** **teaspoon salt**
- 1** **large egg, lightly beaten**
- ½** **cup milk (can use whole, 2%, 1% or nonfat)**
- 2** **tablespoons unsalted butter, melted and cooled**
- ¼** **cup freshly grated Parmesan cheese**
- 1** **tablespoon chopped fresh chives**

Place the rack in Position B, and preheat toaster oven to 400°F. Lightly coat a standard 6-cup muffin tin with cooking spray.

In a small mixing bowl, combine the flour, cornmeal, brown sugar, cream of tartar, baking soda and salt; stir to combine and completely break up any lumps in the brown sugar.

In a 1-cup glass measure combine the egg, milk and melted cooled butter. Add the liquid ingredients, the grated Parmesan and the chives all at once to the dry ingredients. Stir until just moistened. Fill the prepared muffin cups with the batter.

Bake in the preheated 400°F oven for about 20 minutes, until lightly browned. Remove from pan and serve warm.

For plain corn muffins, follow the recipe, omitting the Parmesan and chives.

Nutritional information per muffin (made with 2% milk):
Calories 166 (36% from fat) • carb. 22g • pro. 5g • fat 7g • sat. fat 4g
• chol. 50g • sod. 259g • calc. 86mg • fiber 1g

Pesto Cheese Twists

Serve these as an appetizer, or with soup in place of crackers.

Makes sixteen 5-inch twists

- 1 sheet puff pastry, thawed at room temperature for 20 to 30 minutes**
- 1 tablespoon prepared pesto**
- 1 tablespoon grated Parmesan or Asiago cheese**
- 1 egg white, beaten until foamy**

On a lightly floured surface, roll the thawed puff pastry until it measures 10 x 12 inches; use a pastry wheel to cut the puff pastry in half crosswise. Combine the pesto, grated cheese and half the beaten egg white (discard the remaining egg white). Spread the pesto mixture over one of the half-sheets using an offset spatula; top with the second half-sheet. Use a rolling pin to lightly roll together. With the pastry wheel, cut the sheet in half crosswise, then cut each piece into eight strips, 6 x ½ inches each. Twist each strip 3 to 4 times; pinch ends to seal. Place on a tray and refrigerate for at least 30 minutes.

Ten minutes before baking, place the rack in position B; preheat the toaster oven to 425°F. Line the broiler pan (without drip tray) with a sheet of parchment paper.

Arrange 8 puff pastry twists evenly on the parchment-lined pan. Bake for 11 to 13 minutes at 425° F until puffed and crispy. Remove from the pan with tongs or a spatula and place on a rack to cool. Arrange the second batch on the same pan and repeat. Serve slightly warm or at room temperature.

Nutritional information per twist:
Calories 84 (51% from fat) • carb. 9g • pro. 2g • fat 5g • sat. fat 1g
• chol. 0 mg • sod. 66mg • calc. 8mg • fiber 0g

Quick Cheese Nachos

Homemade nachos make a great quick snack or appetizer. Serve with sour cream, guacamole and your favorite salsa.

Makes 2 servings

- 15 full-sized baked tortilla chips (about 2½ ounces)**
- ⅔ cup refried beans**
- ¼ cup jalapeño pepper slices, drained**
- ¼ cup chopped scallions**
- ¼ cup sliced black olives, drained**
- 1 cup shredded extra-sharp cheddar cheese (can use lowfat)**

Place rack in Position A and preheat on broil setting.

Arrange chips in 11x7-inch baking pan that has been lined with foil. Distribute the remaining ingredients over the chips, as evenly as possible in the order listed, ending with the shredded cheese. Place in the oven and broil until cheese is bubbly, about 4 minutes. Serve immediately.

Nutritional information per serving (made with lowfat cheese):
Calories 543 (40% from fat) • carb. 43g • pro. 39g • fat 25g • sat. fat 1g
• chol. 60mg • sod. 1560mg • calc. 910mg • fiber 4g

MELTED CHEESE SANDWICHES

The next two sandwiches are classic toaster-oven fare, quick and easy hot sandwiches for any time of day or night.

Toasted Crab & Cheddar Melts

A classic open-faced toasted sandwich. Serve with a green salad for supper, or for Sunday brunch.

Makes 4 open-faced sandwiches

- 2 sandwich-size English muffins, split**
- 12 ounces lump crab meat, drained**
- ½ cup finely chopped celery**
- ⅓ cup chopped parsley**
- 2 tablespoons finely chopped green onion**
- ½ cup lowfat mayonnaise**
- 1 cup shredded sharp Cheddar cheese (can use lowfat)**

Toast English muffin in toaster oven on light setting; let cool completely. Line the baking pan with foil; preheat toaster oven on broil setting.

Pick crab over carefully to remove shell and cartilage bits, taking care not to break up large lumps, and place in a medium bowl. Add celery, parsley, green onion, mayonnaise and half the cheese. Stir gently to combine.

Divide crab mixture evenly among the four toasted English muffin halves and spread evenly. Sprinkle each with ¼ of the remaining cheese. Arrange the sandwiches on the prepared baking tray. Broil until golden, toasty, hot, and cheese is melted, about 4 to 5 minutes.

Nutritional information per serving (one open-faced sandwich):
Calories 355 (42% from fat) • carb. 33g • pro. 29g • fat 16g • sat. fat 2g
• chol. 102mg • sod. 808mg • calc. 360mg • fiber 2g

Hot Smoked Turkey & Havarti Sandwiches with Avocado

Makes 4 open-faced sandwiches

- 4 slices good quality whole wheat or pumpernickel bread (about 5 x 3½ x ½-inches)**
- 6 tablespoons lowfat mayonnaise**
- 1 tablespoon Dijon-style mustard**
- 1 tablespoon chopped fresh parsley**
- 1½ teaspoons tarragon**
- ⅛ teaspoon freshly ground pepper**
- 12 ounces thinly sliced smoked turkey**
- 12-16 thin slices Italian tomato (slice, then place on layered paper towels to drain)**
- 6 ounces sliced Havarti cheese (can also use Cheddar, Swiss, provolone, Gouda)**
- 1 avocado (ripe but firm), peeled and sliced**

Toast bread on medium setting (or to taste). Reserve.

Preheat toaster oven to 400°F. Line baking pan with foil. In small bowl, combine mayonnaise, mustard, parsley, tarragon, and pepper; mix well.

Spread mayonnaise mixture on one side of each slice of toasted bread. Top each evenly with one quarter of the smoked turkey, one quarter of the sliced tomatoes, and one quarter of the cheese. Place on foil-lined baking pan, evenly spaced. Place in toaster oven and bake until cheese is bubbly and browned, about 4 to 6 minutes. Garnish with sliced avocado and serve hot.

Nutritional information per serving (one open-faced sandwich):
Calories 493 (55% from fat) • carb. 25g • pro. 19g • fat 29g • sat. fat 13g
• chol. 92mg • sod. 1329mg • calc. 258mg • fiber 6g

Soy Glazed Salmon with Dijon-Dill Sauce

The Dijon-dill sauce may be made ahead if you are entertaining.

Makes 4 servings

- ¾ cup nonfat plain yogurt* or whole sour cream****
- ½ cup grainy Dijon-style mustard**
- 2 tablespoons extra virgin olive oil**
- 1 small shallot (½ ounce), peeled and finely chopped**
- ¾ ounce fresh dill weed, finely chopped**
- 2 teaspoons sugar**
- 1 teaspoon kosher salt, divided**
- ½ teaspoon freshly ground black pepper**
- 4 6-ounce portions salmon fillet, skin on**
- 1 tablespoon soy sauce**

Place the yogurt, mustard, olive oil, shallot, dill weed, sugar, ½ teaspoon salt, and ¼ teaspoon pepper in a medium bowl. Stir with a whisk to blend. Let stand 30 minutes or longer to allow flavors to develop. The sauce may be done up to a day ahead. Makes about 1¼ cups sauce.

Brush the salmon fillets with the soy sauce and sprinkle with the remaining salt and pepper. Let sit for 15 minutes at room temperature. Place the rack in the toaster oven in position B and preheat on the broil setting. Place the drip pan in the broiling pan so that the fish will be about 1½ to 2 inches from the upper element. Lightly coat the broiler rack with cooking spray and add ¼ cup of water to the drip pan. Arrange the salmon fillets skin down on the prepared pan. Place in the oven and broil with the oven door ajar for 14 to 18 minutes; salmon should test 145°–150°F when tested with an instant-read thermometer. Serve hot or chilled with the Dijon-dill sauce.

*For a thicker sauce, strain the yogurt for 1 hour or longer using a yogurt strainer or a strainer lined with a coffee filter; discard the whey (liquid).

**For a richer sauce, use whole sour cream.

Nutritional information per serving (sauce made with nonfat yogurt):
Calories 321 (36% from fat) • carb. 14g • pro. 36g • fat 13g • sat. fat 2g
• chol. 89mg • sod. 1448mg • calc. 86mg • fiber 0g

Oven Baked Scampi

Serve over linguine cooked al dente, or with crusty bread to dip in the sauce.

Makes 2 to 3 servings

- 1 pound large (21-30 count) shrimp**
- 2 tablespoons unsalted butter, melted**
- 2 tablespoons extra virgin olive oil**
- 2 tablespoons finely minced shallot**
- 1-2 cloves garlic, peeled and finely minced**
- 1 teaspoon herbes de Provence or Italian herb blend**
- ½ teaspoon dry mustard**
- ¼ teaspoon kosher salt**
- ⅙ teaspoon freshly ground black pepper**
- ¼ cup dry vermouth**
- ⅓ cup fresh bread crumbs**
- 2 tablespoons chopped fresh Italian parsley**
- 1 tablespoon freshly squeezed lemon juice**
- lemon wedges**

Peel shrimp, leaving tail on. De-vein and partially butterfly; reserve. Preheat toaster oven to 425°F.

Combine melted butter, olive oil, shallot, garlic, herbes de Provence, dry mustard, salt, and pepper. Spread half of this mixture in a 1¼-quart oven-proof oval dish. Arrange shrimp evenly over the butter/oil mixture. Pour the vermouth and the remaining butter/oil mixture over the shrimp. Bake for 8 to 9 minutes. Remove from oven, stir gently to loosen – shrimp should be beginning to curl and be somewhat opaque and “shrimp” in color. Sprinkle evenly with breadcrumbs and half the chopped parsley. Return to the oven for an additional 3 to 4 minutes.

Remove from oven, drizzle with lemon juice and sprinkle with remaining chopped parsley. Serve with additional lemon wedges.

Nutritional information per serving (3 servings):
Calories 366 (47% from fat) • carb. 11g • pro. 34g • fat 19g • sat. fat 6g
• chol. 316mg • sod. 526mg • calc. 96mg • fiber 1g

Mushroom Meatloaf

This meatloaf makes out-of-this-world sandwiches the next day (if there is any left)!

Makes 6 servings (12 slices)

cooking spray
½ **tablespoon extra virgin olive oil**
4 **ounces mushrooms, thinly sliced or finely chopped**
1 **carrot, peeled and finely chopped**
1 **large celery stalk, finely chopped**
1 **medium onion, finely chopped**
1 **clove garlic, finely minced**
1 **teaspoon thyme**
2 **slices firm white bread, torn into pieces**
½ **cup milk (can use whole, 2%, 1% or nonfat milk)**
1 **large egg**
¾ **pound ground veal**
¾ **pound lean ground pork or dark-meat turkey**
1 **teaspoon kosher salt**
½ **teaspoon freshly ground black pepper**

Place the rack in position A and preheat toaster oven to 350° F. Lightly coat a 6-cup loaf pan (8½x4½x2½ inches) with cooking spray. Heat the oil in a 10-inch skillet over medium heat. Add the mushrooms, carrot, celery, garlic and onion. Cook until tender, 4 to 5 minutes. Add the thyme and cook for 1 minute. Remove from the heat, transfer to a shallow bowl and let cool completely.

Place the torn bread in a large bowl. Stir in the milk and egg, let stand for 2 to 3 minutes. Add the cooled cooked vegetable mixture, the ground meat, salt and pepper; mix well to combine. Pack mixture into the prepared loaf pan. Bake for 1¼ hours. Allow the meatloaf to rest in the pan for 10 minutes. Drain excess fat if necessary, turn the loaf out of the pan and slice to serve.

Nutritional information per serving (2 slices; made with 1% milk):
Calories 312 (54% from fat) • carb. 11g • pro. 24g • fat 19g • sat. fat 7g
• chol. 124g • sod. 329mg • calc. 60mg • fiber 1g

Broiled Hamburgers or Cheeseburgers

Makes 4 burgers

cooking spray
24 **ounces lean ground sirloin or ground round**
kosher salt and freshly ground pepper to taste
4 **slices cheese (Cheddar, Swiss), optional**

Preheat toaster oven on broil setting. Line the baking pan with aluminum foil, and insert baking/broiling rack. Lightly coat the rack with cooking spray.

Divide meat into four 6-ounce portions and shape into 4-inch burgers. Lightly season with kosher salt and freshly ground pepper on both sides. Arrange the burgers, evenly spaced, on the rack. Place in toaster oven and broil to taste*, about 4 to 8 minutes per side. For cheeseburgers, top with sliced cheese one minute before second side is done. Serve hot on toasted bun, roll, or English muffin with desired condiments and accompaniments such as lettuce, sliced tomato, onion, etc.

*Times will be dependent on temperature and thickness of meat. Test with an instant-read thermometer.

Rare: 120°-125°F (red center)

Medium-Rare: 125°-140°F (pink center)

Medium: 145°-155°F (gray-barely pink center)

Well Done: 160°F (gray)

Nutritional information per serving (one hamburger):
Calories 325 (15% from fat) • carb. 0g • pro. 50g • fat 12g • sat. fat 4g
• chol. 133mg • sod. 109mg • calc. 9mg • fiber 0g

Spicy London Broil

This dry rub has bold, spicy flavors – not overbearing, but not for the faint-hearted. If you prefer milder flavors, cut back on the cayenne just a bit.

Makes 4 to 6 servings

- cooking spray**
- 1½ teaspoons ground cumin**
- 1½ teaspoons sugar**
- 1½ teaspoons kosher salt**
- 1¼ teaspoons thyme**
- 1 teaspoon freshly ground black pepper**
- ¼-½ teaspoon cayenne**
- 1½ pounds top round London broil, about 1¼ inches thick**

In a small bowl, combine the cumin, sugar, salt, thyme pepper and cayenne and blend. Rub the spice mixture evenly on the meat. Place on a non-metallic plate, cover with plastic wrap and refrigerate until 20 minutes before cooking. The spice rub may be put on the meat up to 24 hours before cooking. The longer it is on the meat, the more intense the flavor will be.

Place the rack in position B and preheat toaster oven on broil setting, keeping door ajar. Put ¼ cup of water in the bottom of the broiler pan; place the drip tray in the broiling pan so that the meat will be about 1 inch from the upper element. Lightly coat the rack with cooking spray. Arrange the meat on the broiler rack. Broil with the door ajar for 16 to 20 minutes; turn the London broil halfway through cooking time, until meat is done to desired taste*. Let stand for 10 minutes before carving to allow the juices to set; the meat will continue to cook during this time. Test for appropriate doneness with an instant-read thermometer. After the meat has rested, slice across the grain in very thin slices to serve.

*Times will be dependent on temperature and thickness of meat. Test with an instant-read thermometer.

Rare: 120°-125°F (red center)

Medium-Rare: 125°-140°F (pink center)

Medium: 145°-155°F (gray-barely pink center)

Well-Done: 160°F (gray)

Nutritional information per serving (based on 6 servings):
Calories 211 (48% from fat) • carb. 1g • pro. 25g • fat 11g • sat. fat 4g
• chol. 67mg • sod. 392mg • calc. 12mg • fiber 0g

Teriyaki Glazed Chicken Breasts

Make the teriyaki marinade ahead and have it on hand.
Serve with rice and steamed fresh vegetables.

Makes 4 servings

- ½ cup soy sauce (can use low sodium)**
- ¼ cup rice wine vinegar**
- 3 tablespoons dry sherry or mirin**
- 1½ tablespoons finely chopped fresh ginger**
- 3 tablespoons brown sugar**
- 4 boneless, skinless chicken breast halves (about 6 to 8 ounces each)**

In a 1-quart nonreactive saucepan, combine the soy, rice wine vinegar, sherry, ginger, and brown sugar. Bring to a boil, then reduce the heat and simmer for 15 minutes. Strain, discard the solids, and let cool completely.

Rinse the chicken and pat dry. Place the chicken between two sheets of plastic wrap and pound to an even thickness of ½ inch with a flat mallet. Put the flattened chicken breasts in a resealable plastic bag and pour half the teriyaki marinade over them. Press the air out and let marinate for 15 minutes at room temperature. Reserve and refrigerate the remaining marinade in a glass storage jar (it will keep refrigerated for up to 2 weeks).

Place the rack in position C and preheat toaster oven on broil setting, keeping door ajar. Place the drip tray in the broiling pan so that the flattened chicken breast halves will be about 1 inch from the upper element. Add ¼ cup of water to the broiling pan and arrange the chicken “skin” side down on the drip tray. Broil with the door ajar, about 6 to 8 minutes. Turn

chicken and continue cooking until juices run clear, about 6 to 8 minutes longer. (Internal temperature of chicken should be 170°F.)

Nutritional information per serving:
Calories 348 (8% from fat) • carb. 20g • pro. 55g • fat 3g • sat. fat 1g
• chol. 132mg • sod. 2870mg • calc. 49mg • fiber 0g

Lemon Thyme Roast Chicken

Roast a succulent chicken without turning on the large oven.

Makes 2 servings

- cooking spray**
- ½ small broiler/fryer chicken, about 1½ to 2 pounds (no larger)**
- 1 tablespoon extra virgin olive oil**
- 1 tablespoon freshly squeezed lemon juice**
- ½ teaspoon dry thyme***
- ½ teaspoon kosher salt**
- ¼ teaspoon freshly ground black pepper**
- 1 4-inch sprig fresh thyme***
- 1 clove garlic, peeled and cut in half**
- 1 small onion (about 2 ounces), peeled and quartered**
- 4 strips lemon zest (3x½ inches each)**

Place the rack in position A and preheat toaster oven to 400°F.

Rinse chicken with cold water and pat dry. Place the drip tray in the broiling pan in the lower position; add ¼ cup water to the pan and lightly coat with cooking spray.

Rub chicken skin with olive oil and lemon juice. Combine the thyme, salt and pepper. Rub half the mixture in the cavity of the chicken and half on the skin of the chicken. Place the thyme sprig, garlic halves, onion quarters and lemon zest on the prepared pan. Arrange the seasoned chicken on top of the vegetables and herbs, place in toaster oven and roast for 20 minutes, then lower the temperature to 350°F and continue to roast for another 20 to 25 minutes. (Internal temperature of the chicken should be 170°F when tested in the breast, and 180°F when tested in the dark meat; juices should run clear.)

Turn off oven and remove the chicken to a platter. Let stand 10 to 15 minutes before carving (cover loosely with foil if desired, but skin will lose its crispness).

*You can use other herbs such as basil, marjoram, oregano, or rosemary.

Nutritional information per serving:
Calories 576 (66% from fat) • carb. 4g • pro. 44g • fat 42g • sat. fat 11g
• chol. 174mg • sod. 664mg • calc. 39mg • fiber 1g

Chicken, Vegetable & Black Bean Burritos

Makes 4 servings

- cooking spray**
- 2 teaspoons good quality olive oil**
- 2 cups shredded zucchini**
- 8 green onions, trimmed and chopped**
- ¼ cup chopped flat parsley or cilantro**
- 1 can (15-ounce) black beans, drained, rinsed and drained again**
- ¼ teaspoon kosher salt**
- 2 cups shredded cooked chicken**
- 1 tomato (6 ounces), cored, seeded and chopped**
- 1 jalapeño pepper, seeded and chopped**
- 2 tablespoons fresh lime juice**
- 8 ounces shredded low-fat Cheddar or Monterey Jack cheese (about 2 cups)**
- 4 9-inch flour tortillas (can use flavored such as sun-dried tomato) guacamole, sour cream and salsa for garnish**

Place the rack in position B and preheat toaster oven to 350°F. Spray a 7x11-inch baking dish with cooking spray, or rub with olive oil.

In a medium nonstick skillet, heat half the olive oil over medium heat. Add the shredded zucchini and cook until lightly browned, tender and no longer watery, about 8 to 10 minutes. Stir in one quarter of the green onions and half the chopped parsley/cilantro. Remove and reserve. Heat remaining oil in the pan over medium heat. Add a third of the remaining green onions,

the remaining chopped parsley, drained white beans and salt to the pan. Cook for 2 to 3 minutes. Use the back of a wooden spoon or a potato masher to mash the beans (the beans should be just partially mashed), and cook until heated through, about 3 to 4 minutes. Transfer to a bowl and let cool. Place the shredded chicken in a medium bowl. Stir in the chopped tomato, chopped jalapeño, lime juice, half the cheese and half of the remaining green onions.

Spread one quarter of the bean mixture in a line just below the center of each tortilla. Top each with one quarter of the cooled zucchini and one quarter of the chicken mixture. Sprinkle each with 2 tablespoons of the remaining cheese. Roll the burritos and place them seam side down in the prepared baking dish. Cover with a sheet of foil that has been sprayed with cooking spray; bake for 15 minutes. Remove the foil and sprinkle evenly with the remaining cheese and chopped green onions. Continue to bake until the cheese is melted, about 12 to 15 minutes longer. Serve with guacamole, salsa and sour cream for garnish.

Nutritional information per burrito:

*Calories 529 (31% from fat) • carb. 38g • pro. 55g • fat 19g • sat. fat 2g
• chol. 114mg • sod. 997mg • calc. 513mg • fiber 6g*

Oven Roasted BBQ Baby Back Ribs

Makes 2 to 4 servings

- 2** cooking spray
- 2** racks pork baby back ribs, about 8 ribs each (1¾ to 2 pounds total)
- ½ teaspoon kosher salt
- ½ teaspoon dried minced onion
- ½ teaspoon thyme
- ¼ teaspoon granulated garlic
- ¼ teaspoon paprika
- ¼ teaspoon freshly ground black pepper
- barbecue sauce, homemade or purchased**

Place the rack in position A and preheat toaster oven to 375°F.

Place roasting rack in baking pan. Lightly coat with cooking spray. Remove “paper” skin from underside of ribs. Combine salt, minced onion, thyme, garlic, paprika, and black pepper. Rub evenly over both sides of each rack of ribs. Arrange ribs on prepared roasting rack. Cover loosely with foil and bake for 50 to 60 minutes.

Remove ribs from oven. Increase oven temperature to 450°F. Turn ribs over and brush with half the BBQ sauce. Roast for 12 to 15 minutes. Turn, coat top of ribs with sauce and roast for an additional 12 to 15 minutes. Remove from oven and let rest for 10 minutes. Cut into individual ribs and serve. You can heat additional sauce to serve with ribs.

Nutritional information per serving, without barbecue sauce:

*Calories 549 (71% from fat) • carb. 1g • pro. 39g • fat 42g • sat. fat 15g
• chol. 156mg • sod. 299mg • calc. 66mg • fiber 0g*

Asian 5-Spice Pork Tenderloin

Makes 4 to 6 servings

- 2** tablespoons light soy sauce
- 2** tablespoons brown sugar
- 1** tablespoon hoisin sauce
- 1** tablespoon dry sherry or mirin
- 1** tablespoon minced fresh ginger
- 1** tablespoon minced green onion
- 2** teaspoons Asian toasted sesame oil*
- 1-2** cloves garlic, peeled and minced
- ½ teaspoon 5-spice powder*
- ½ teaspoon kosher salt
- 1** pork tenderloin, about 1¼ to 1½ pounds
- ½ cup chicken stock

Combine the soy sauce, brown sugar, hoisin sauce, sherry, ginger, green onion, sesame oil, garlic and 5-spice powder in a resealable freezer-weight bag and stir. Trim any excess fat and silver skin from the pork tenderloin. Place the pork tenderloin in the marinade for 30 minutes at room temperature or up to 8 hours in the refrigerator.

Place the rack in position A and preheat toaster oven to 450°F. Line the baking pan with foil; then place the roasting rack in the pan.

Remove tenderloin from marinade, allowing excess to drain off. Place excess marinade in a small saucepan with the chicken stock. Turn the narrow end of the tenderloin under and attach with a toothpick or skewer so that the tenderloin is an even thickness.

Roast the tenderloin for 15 to 18 minutes, turning after 9 minutes. While the pork is roasting, heat the reserved marinade until it bubbles for 5 minutes; lower heat and cook until reduced by half and thickened – this can be served as a sauce for the pork. When pork has reached an internal temperature of 150°F when tested with an instant-read thermometer, remove it from oven. Cover loosely and let rest for 10 to 15 minutes before slicing. Slice the tenderloin crosswise into thin slices and serve with sauce.

*Can be found in most well-stocked grocery stores or in any Asian grocery store.

Nutritional information per serving (6 servings):
Calories 166 (29% from fat) • carb. 6g • pro. 22g • fat 5g • sat. fat 1g
• chol. 58mg • sod. 706mg • calc. 17mg • fiber 0g

Baked Potatoes

Why turn on the big oven just to bake potatoes when the toaster oven does such a good job?

Makes 4 servings

- 4 Idaho or russet potatoes, (8-11 ounces each)**
1 teaspoon extra virgin olive oil

Place the rack in position B and preheat the toaster oven to 400°F. Scrub the potatoes thoroughly and dry. Lightly rub each potato with ¼ teaspoon of the olive oil. Use a fork to prick potatoes, about 6 to 8 times. Place directly on the rack and bake until soft and easily pierced with a knife, about 55 to 60 minutes. Remove from the oven.

To serve, pinch open the top, fluff the interior with a fork and serve topped with butter, extra virgin olive oil, margarine, or sour cream, as desired. Add kosher or sea salt and freshly ground pepper to taste.

Variation: Substitute sweet potatoes or yams for baking potatoes.

Nutritional information per serving (8-oz. potato):
Calories 167 (1% from fat) • carb. 36g • pro. 4g • fat 1g • sat. fat 0g
• chol. 0mg • sod. 12mg • calc. 14mg • fiber 5g

Twice Baked Sour Cream & Chive Potatoes

Makes 4 servings

- 4 Idaho or russet potatoes, about 7-8 ounces each**
⅓ cup lowfat milk
1 tablespoon + 1 teaspoon unsalted butter
½ cup sour cream or lowfat sour cream
¼ teaspoon kosher salt
¼ teaspoon freshly ground pepper (black or white)
3 tablespoons + 1 tablespoon chopped fresh chives

Prepare and bake potatoes as in Baked Potatoes (previous recipe), but do not pinch open – just slit slightly with a knife to allow steam to vent. When cool enough to handle, cut off top quarter of each potato and scoop out cooked potato, leaving a ¼-inch-thick potato shell. Reserve cooked potato and skin shells. Preheat toaster oven to 375°F.

Place cooked potato in a medium bowl. Add milk and 1 tablespoon butter. Using a potato masher or hand mixer, mash/beat until smooth. Add sour cream, salt, pepper, and 3 tablespoons chives. Mash/beat to combine completely. Generously fill the potato shells with sour cream and chive potato mixture. (Potatoes may be prepared a day ahead to this point – cover and refrigerate.) Arrange potatoes on baking tray (can line with a sheet of aluminum foil). Melt remaining teaspoon of butter and drizzle on potatoes. Bake for 35 to 45 minutes (add 5 to 10 minutes to baking time if potatoes were prepared ahead and refrigerated), until potatoes are hot and

golden on the tops. Sprinkle hot potatoes with remaining tablespoon of chopped chives to serve.

Nutritional information per serving (8-ounce potato):
Calories 263 (35% from fat) • carb. 38g • pro. 6g • fat 10g • sat. fat 6g
• chol. 25mg • sod. 121mg • calc. 76mg • fiber 3g

Herb Roasted Sweet Potato Wedges

Sweet potatoes are one of the most nutritious vegetables – and they are delicious when roasted with olive oil and herbs.

Makes 2 to 4 side dish servings

- cooking spray**
- 2 sweet potatoes, about 1 pound total**
- 1 tablespoon extra virgin olive oil**
- ½ teaspoon dry herbs (thyme, rosemary, basil, oregano, savory)**
- ½ teaspoon kosher salt**

Preheat toaster oven to 425°F. Line the baking pan with aluminum foil. Lightly coat with cooking spray.

Scrub the sweet potatoes and trim as necessary; do not peel. Cut potato in half lengthwise. Cut each half into four equal wedges. Toss potato wedges in olive oil, herbs and salt. Arrange on prepared pan and bake for 20 to 25 minutes until potato wedges are tender, browned and crispy. Serve hot.

Note: You may also prepare this recipe using russet potatoes, new red or white potatoes, or Yukon gold potatoes. Cooking times will vary depending on potato used.

Nutritional information per serving (4 servings):
Calories 162 (19% from fat) • carb. 31mg • pro. 2g • fat 5g • sat. fat 0g
• chol. 0mg • sod. 176mg • calc. 20mg • fiber 4g

Savory Fontina & Prosciutto Bread Pudding

A great side dish, brunch dish, or even supper when served with a green salad.

Makes 6 to 8 servings

- cooking spray**
- 1 teaspoon extra virgin olive oil**
- 1 cup chopped onion**
- 6 slices prosciutto, cut in slivers**
- ½ teaspoon Italian herbs or herbes de Provence**
- 4 cups bread cubes (½-inch) from crusty French or Italian bread**
- 1 cup (4 ounces) shredded fontina cheese**
- 2 tablespoons freshly grated Reggiano Parmigiano cheese**
- 4 large eggs (can use egg substitute)**
- 2 cups fat-free evaporated milk (can use half-and-half)**
- ½ teaspoon (or to taste) Tabasco® or other hot sauce**

Lightly coat an 8-cup (8-inch square, round or oval gratin) ovenproof ceramic dish with cooking spray. Heat olive oil in a 10-inch non-stick skillet over medium heat and add chopped onion and prosciutto to pan. Cook, stirring, over medium heat until onion is translucent and prosciutto just begins to curl. Stir in herbs and let cool.

Place bread cubes in a medium bowl with cheeses. Stir to combine. Add cooled onion mixture and combine. Transfer to the prepared baking dish. In the bowl, whisk the eggs until smooth. Add the evaporated milk and whisk until blended. Add hot sauce and blend. Slowly pour over bread mixture. Press mixture lightly with the back of a spoon and allow to rest for at least 1 hour before baking (can be prepared several hours ahead or the night before). Lightly coat a sheet of aluminum foil with cooking spray and cover dish loosely, sprayed side down.

Preheat toaster oven to 375°F. Bake covered bread pudding for 50 to 55 minutes. Uncover and bake for an additional 15 minutes. Let rest 10 minutes before serving.

Tabasco® is a registered trademark owned by McIlhenny Co.

Nutritional information per serving (based on 8 servings):
Calories 480 (28% from fat) • carb. 60g • pro. 26g • fat 15g • sat. fat 7g
• chol. 149mg • sod. 512mg • calc. 389mg • fiber 2g

Tomato-Potato Gratin

A slight change from traditional potatoes au gratin, these are excellent served with grilled swordfish or steak.

Makes 6 servings

- 1½** tablespoons extra virgin olive oil
- 2** medium onions, cut into thin slices
(can use 3-mm slicing disc of Cuisinart® food processor)
- 1½** cups chopped plum tomatoes
(3-4 tomatoes, cored and seeded)
- ¾** teaspoon kosher salt
- 1** teaspoon fresh rosemary (½ teaspoon dried), chopped
- ½** teaspoon fresh thyme (¼ teaspoon dried), chopped
- ¼** teaspoon freshly ground black pepper
- ⅓** cup grated Parmesan or Asiago
- 1½** pounds baking potatoes, scrubbed, peeled if desired, cut into ⅛-inch slices (can use 3 or 4mm slicing disc of the Cuisinart food processor)

Place the rack in position B and preheat toaster oven to 400°F. Brush an 8x11-inch oval or 8x8-inch square baking dish with olive oil.

In a 12-inch nonstick fry pan, heat the olive oil over moderately low heat. Add the onions and cook, stirring occasionally, until they are translucent, about 5 minutes. Remove from the heat and stir in the chopped plum tomatoes and ¼ teaspoon of the salt.

In a small bowl, combine the rosemary, thyme, remaining salt, pepper and cheese. Spread half the tomato/onion mixture in the prepared baking dish. Layer half the potato slices evenly on top. Sprinkle with half the herb and Parmesan mixture. Repeat. Cover with aluminum foil and bake for 40 to 45

minutes, until potatoes are tender when tested with a fork. When tender, remove the foil and bake for an additional 15 to 20 minutes, until the potatoes are golden.

Nutritional information per serving:
Calories 167 (27% from fat) • carb. 26g • pro. 5g • fat 5g • sat. fat 1g
• chol. 4mg • sod. 273mg • calc. 90mg • fiber 3g

Summertime Zucchini, Tomato & Basil Bake

While this side dish is best in the summer with garden fresh vegetables, our markets make it easy to get these ingredients all year 'round.

Makes 4 servings

- 2** medium green zucchini, each 1½ inches in diameter
- 6** ripe plum tomatoes
- 10** large fresh basil leaves
- 1** large clove garlic, peeled and halved
- 1** tablespoon extra virgin olive oil
- ½** teaspoon kosher salt
- ¼** teaspoon freshly ground pepper
- ¼** cup freshly grated Reggiano Parmesan cheese

Preheat the toaster oven to 350°F.

Trim the ends of the zucchini. Cut into ¼-inch-thick slices. Cut the tomatoes into ¼-inch-thick slices. (This can be done using a Cuisinart® food processor and the 6mm slicing disc.) Stack the basil, roll, then cut into very thin strips with a sharp knife to produce a shred. Set aside.

Rub the garlic clove over the bottom of an 8x8-inch glass or ceramic baking dish, and discard the garlic. Brush with 1 teaspoon of the olive oil.

Arrange the zucchini and tomato slices in a single layer, overlapping them tightly. Season with the salt and pepper. Scatter the shredded basil evenly over the zucchini and tomatoes. Drizzle with the remaining olive oil, then sprinkle evenly with the grated cheese.

Bake for 25 to 30 minutes, until the zucchini is tender. Serve hot or at room temperature.

Nutritional information per serving:
Calories 89 (52% from fat) • carb. 7g • pro. 4g • fat 6g • sat. fat 2g
• chol. 5mg • sod. 286mg • calc. 96mg • fiber 3g

Orzo-Stuffed Squash

This is a perfect complement to grilled meats or seafood, or a delicious vegetarian entrée.

Makes 4 servings

- cooking spray**
- 4 medium yellow squash (6-8 ounces each)**
- 2 teaspoons + 1 teaspoon extra virgin olive oil**
- 1 clove garlic, chopped**
- ½ cup minced red onion**
- ½ cup finely chopped red bell pepper**
- 1 teaspoon basil**
- 1 cup cooked orzo, pastina, or rice**
- 1 tablespoon chopped flat parsley**
- ½ teaspoon kosher salt**
- ¼ teaspoon freshly ground black pepper**
- 3 ounces shredded sharp Cheddar cheese (can use reduced fat)**

Steam squash for 12 to 15 minutes until crisp-tender. When cool enough to handle, cut a lengthwise strip from the top of each squash and reserve; scoop out the pulp from the lids and the shells, discarding the seeds and leaving ¼-inch-thick shells. Invert the shells on a cooling rack over a towel and let drain for 30 minutes. Chop the squash lids and reserve.

Melt 2 teaspoons olive oil in a 10-inch nonstick skillet over medium heat. Add the chopped garlic, onion and pepper and cook until tender, 3 to 5 minutes. Stir in the reserved chopped basil, chopped squash, orzo or rice, parsley, salt and pepper. Remove from the heat and let cool for 5 minutes.

Stir in the shredded cheese. Rub each squash shell with ¼ teaspoon extra virgin oil. Stuff the squash shells generously with the orzo/vegetable mixture. The recipe may be done ahead to this point, covered and refrigerated.

Place the rack in position A and preheat toaster oven to 400°F. Lightly coat an 11x7-inch baking dish with cooking spray. Arrange the stuffed squash in the baking dish. Bake until the squash are golden brown and heated through, 20 to 25 minutes. Serve hot.

Nutritional information per serving:
Calories 185 (36% from fat) • carb. 21g • pro. 9g • fat 8g • sat. fat 1g
• chol. 11mg • sod. 274mg • calc. 205mg • fiber 5g

Cranberry Ginger Apple Crisp

An old favorite with a twist – dried cranberries and bits of crystallized ginger.

Makes 8 servings

- cooking spray**
- 1 cup rolled oats**
- ½ cup brown sugar, packed**
- ⅓ cup all-purpose flour**
- 1 teaspoon cinnamon**
- ¼ teaspoon salt**
- 6 tablespoons unsalted butter, melted (¾ stick)**
- 1½ pounds tart apples, peeled, cored, quartered and cut into ¼-inch slices***
- 1 tablespoon freshly squeezed lemon juice**
- ½ cup dried cranberries**
- 2 tablespoons chopped crystallized ginger**
- ½ cup granulated sugar**
- 2 tablespoons honey**
- 1 teaspoon vanilla**

Place the rack in position A and preheat the toaster oven to 350°F. Lightly coat an 8x8-inch (6-cup) glass or ceramic baking dish with cooking spray.

In a medium bowl, combine the rolled oats with the brown sugar, flour, cinnamon and salt. Add the melted butter and stir until the mixture is evenly moistened. Use your fingers to pinch the mixture into large crumbs.

In a medium bowl, toss the sliced apples with the lemon juice, cranberries, chopped ginger, granulated sugar, honey, and vanilla. Spoon the apple mixture evenly in the prepared baking dish. Sprinkle evenly with the reserved crumb mixture.

Bake for 40 to 45 minutes, until the apples are tender and the filling is bubbling. Let rest for 20 to 30 minutes before serving. Serve warm or at room temperature with vanilla ice cream or frozen yogurt, or freshly whipped cream.

*For ease in slicing, use the Cuisinart® food processor fitted with the 4mm slicing disc.

Nutritional information per serving:
Calories 334 (27% from fat) • carb. 57g • pro. 2g • fat 9g • sat. fat 6g
• chol. 23mg • sod. 82mg • calc. 36mg • fiber 4g

Chocolate Chip Brownie Pie

This old favorite is pure comfort food.

Serves 8 to 10

cooking spray
2 large eggs
½ cup granulated sugar
½ cup packed light brown sugar
½ cup unsalted butter, melted (1 stick)
½ cup all-purpose flour
⅓ cup unsweetened cocoa
½ teaspoon salt
2 teaspoons vanilla extract

¾ cup semisweet chocolate chips
1 cup coarsely chopped pecans or walnuts

Place the rack in position B and preheat the toaster oven to 350°F. Lightly coat a 9-inch pie tin with cooking spray.

Beat the eggs in a medium bowl until frothy. Stir in the sugars, beat until smooth. Stir in the melted butter. Add the flour, cocoa and salt; stir to combine. Add the vanilla, chocolate chips and nuts; stir. Pour into the prepared pan.

Bake for 22 to 25 minutes, until just barely set (pie will not test done in the center – do not overbake). Remove from the oven and let cool completely on a rack before cutting. If you wish to serve it warm, let it cool to set, then re-warm gently for about 10 to 5 minutes at 200°F. Cut into wedges and serve. Very good when topped with ice cream or frozen yogurt, and a drizzle of fudge or chocolate sauce.

Variation: Substitute milk chocolate, white chocolate, peanut butter or butterscotch chips for the chocolate chips; substitute other nuts such as peanuts, hazelnuts or almonds.

Nutritional information per serving (based on 10 servings):
Calories 3681 (53% from fat) • carb. 39g • pro. 6g • fat 22g • sat. fat 9g
• chol. 67mg • sod. 136mg • calc. 30mg • fiber 3g

Raspberry Almond Oat Bars

Makes 16 bars

cooking spray
1 cup rolled oats
1 cup all-purpose flour
⅔ cup packed light brown sugar
¼ teaspoon baking soda
¼ teaspoon salt
1½ teaspoons vanilla
½ cup unsalted butter, cut in ½-inch pieces

-
- ¼ cup chopped almonds
1 jar (10-ounce) raspberry preserves (about 1 cup)

Place the rack in position B and preheat the toaster oven to 325°F. Lightly spray a 7x11-inch baking pan with cooking spray.

Place oats, flour, brown sugar, baking soda and salt in a medium bowl and stir to blend. Add vanilla and butter, and using a pastry blender or two forks, cut butter into dry ingredients until the mixture is evenly moist and crumbly. Remove ½ cup of the mixture. Stir chopped nuts into one of the half cups of the crumb mixture and reserve for topping.

Press the oatmeal mixture without the nuts evenly into the prepared baking pan. Spread the raspberry preserves over the top. Sprinkle with the reserved oat/nut mixture. Bake for 20 to 25 minutes, or until golden. Let cool completely in the baking pan set on a wire rack. Cut into bars.

Nutritional information per bar:
Calories 199 (32% from fat) • carb. 32g • pro. 2g • fat 7g • sat. fat 4g
• chol. 16mg • sod. 60mg • calc. 18mg • fiber 1g

WARRANTY

LIMITED THREE-YEAR WARRANTY

This warranty supersedes all previous warranties on the Cuisinart® Classic Toaster Oven Broiler.

This warranty is available to consumers only. You are a consumer if you own a Cuisinart® Classic Toaster Oven Broiler that was purchased at retail for personal, family or household use. Except as otherwise required under applicable state law, this warranty is not available to retailers or other commercial purchasers or owners.

We warrant that your Cuisinart® Classic Toaster Oven Broiler will be free of defects in material or workmanship under normal home use for three years from the date of original purchase.

We suggest that you complete and return the enclosed product registration card promptly to facilitate verification of the date of original purchase. However, return of the product registration is not a condition of these warranties.

If your Cuisinart® Classic Toaster Oven Broiler should prove to be defective within the warranty period, we will repair it, or if we think necessary, replace it. To obtain warranty service, please call our Consumer Service Center toll-free at 1-800-726-0190 or write to:

Cuisinart
150 Milford Road
East Windsor, NJ 08520

To facilitate the speed and accuracy of your return, please also enclose \$10.00 for shipping and handling of the product (California residents need only supply proof of purchase and should call 1-800-726-0190 for shipping instructions). Please also be sure to include a return address, description of the product defect, product serial number, and any other information pertinent to the product's return. Please pay by check or money order.

NOTE: For added protection and secure handling of any Cuisinart® product that is being returned, we recommend you use a traceable, insured delivery service. Cuisinart cannot be held responsible for in-transit damage or for packages that are not delivered to us. Lost and/or damaged products are not covered under warranty.

Your Cuisinart® Classic Toaster Oven Broiler has been manufactured to strict specifications and has been designed for use with the Cuisinart® Classic Toaster Oven Broiler accessories and replacement parts. These warranties expressly exclude any defects or damages caused by accessories, replacement parts or repair service other than those that have been authorized by Cuisinart.

These warranties do not cover any damage caused by accident, misuse, shipment or other than ordinary household use.

These warranties exclude all incidental or consequential damages. Some states do not allow the exclusion of or limitation of incidental or consequential damages, so the foregoing limitation may not apply to you.

CALIFORNIA RESIDENTS ONLY

California law provides that for In-Warranty Service, California residents have the option of returning a nonconforming product (A) to the store where it was purchased or (B) to another retail store which sells Cuisinart® products of the same type. The retail store shall then, according to its preference, either repair the product, refer the consumer to an independent repair facility, replace the product, or refund the purchase price less the amount directly attributable to the consumer's prior usage of the product. If either of the above two options does not result in the appropriate relief to the consumer, the consumer may then take the product to an independent repair facility if service or repair can be economically accomplished. Cuisinart and not the consumer will be responsible for the reasonable cost of such service, repair, replacement, or refund for nonconforming products under warranty.

California residents may also, according to their preference, return nonconforming products directly to Cuisinart for repair or, if necessary, replacement by calling our Consumer Service Center toll-free at 800-726-0190. Cuisinart will be responsible for the cost of the repair, replacement, and shipping and handling for such nonconforming products under warranty.

BEFORE RETURNING YOUR CUISINART® PRODUCT

Important: If the nonconforming product is to be serviced by someone other than Cuisinart's Authorized Service Center, please remind the servicer to call our Consumer Service Center to ensure that the problem is properly diagnosed, the product serviced with the correct parts, and to ensure that the product is still under warranty.

Cuisinart®

SAVOR THE GOOD LIFE®



Wafflemakers



Food Processors



Toasters



Blenders



Cookware



Ice Cream Makers

Cuisinart offers an extensive assortment of top quality products to make life in the kitchen easier than ever. Try some of our other countertop appliances and cookware, and Savor the Good Life®.

www.cuisinart.com

© 2005 Cuisinart
Cuisinart® is a registered trademark of Cuisinart
150 Milford Road
East Windsor, NJ 08520
Printed in China
05CU26057

A IB-5946

Starlite Electronic Pre-Press System

Reference: TOB50 IB-5946
Size: 229 mm X152 (mm) (NEW)
Material: Cover: 157GSM MATT ARTPAPER
Inside: 120GSM GLOSS ARTPAPER
Coating: VARNISHING IN COVER
Color: COVER: 4C+1C(BLACK); INSIDE: 1C+1C(BLACK)
Date: 2005-04-30

Client: G0028
Starlite No: 862191BB
Proof: 1ST
Handled By:Z009028

Cyan Magenta Yellow Black

5	10	20	30	40	50	60	70	80	90	100
5	10	20	30	40	50	60	70	80	90	100
5	10	20	30	40	50	60	70	80	90	100
5	10	20	30	40	50	60	70	80	90	100